

THE BIOTECHNOLOGY  
EDUCATION COMPANY®

REVISED  
&  
UPDATED

Edvo-Kit #  
**371**

Edvo-Kit #371

## DNA Fingerprinting Using PCR

**LyphoTemplate™**

**LyphoPrimer™**

### Experiment Objective:

In this experiment, students will conduct a DNA fingerprinting exercise on simulated samples from a crime scene and four different suspects. Polymorphic regions of DNA are amplified using PCR. Students will then analyze the amplified DNA segments by agarose gel electrophoresis.

See page 3 for storage instructions.



**NOTE:**  
PCR Cycling Conditions have changed. Please review your PCR program before performing the experiment.

# Table of Contents

	Page
Experiment Components	3
Experiment Requirements	4
Background Information	5
Experiment Procedures	
Experiment Overview	9
Module I: PCR Amplification of Crime Scene & Suspect DNA	10
Module II: Separation of PCR Products by Electrophoresis	11
Module III: Staining with FlashBlue™ (OPTIONAL)	14
Study Questions	15
Instructor's Guidelines	16
Pre-Lab Preparations	17
Experiment Results and Analysis	20
Study Questions and Answers	21
Appendices	22

Safety Data Sheets can be found on our website: [www.edvotek.com/safety-data-sheets](http://www.edvotek.com/safety-data-sheets)

## EDVO-TECH Service

**1.800.EDVOTEK**

Mon. - Fri. 8am-5:30pm EST



### Please Have the Following Info:

- Product Number & Description
  - Lot Number on Box
- Order/Purchase Order #
- Approx. Purchase Date

Fax: 202.370.1501 • [info@edvotek.com](mailto:info@edvotek.com) • [www.edvotek.com](http://www.edvotek.com)

[www.edvotek.com](http://www.edvotek.com)

- Online Catalog
- Order Products
- Experiment Protocols
- Tech Support
- Resources!



1.800.EDVOTEK • Fax 202.370.1501 • [info@edvotek.com](mailto:info@edvotek.com) • [www.edvotek.com](http://www.edvotek.com)

Duplication of any part of this document is permitted for non-profit educational purposes only. Copyright © 2006-2015 EDVOTEK, Inc., all rights reserved. 371.181117

## Experiment Components

Components	Storage	Check (✓)
A LyphoPrimer™ Mix	-20°C, desiccated	<input type="checkbox"/>
B EdvoQuick™ DNA Ladder	-20°C	<input type="checkbox"/>
C DNA Template #1	-20°C, desiccated	<input type="checkbox"/>
D DNA Template #2	-20°C, desiccated	<input type="checkbox"/>
E DNA Template #3	-20°C, desiccated	<input type="checkbox"/>
F DNA Template #4	-20°C, desiccated	<input type="checkbox"/>
G TE Buffer	-20°C	<input type="checkbox"/>
• PCR EdvoBeads™	Room Temp.	<input type="checkbox"/>

(Each PCR EdvoBead™ contains: dNTP Mixture, Taq DNA Polymerase Buffer, Taq DNA Polymerase, MgCl<sub>2</sub>, and Reaction Buffer)

Experiment #371 contains enough reagents to amplify 25 DNA samples using the Polymerase Chain Reaction. This represents five complete sets of reactions.

All experiment components are intended for educational research only. They are not to be used for diagnostic or drug purposes, nor administered to or consumed by humans or animals.

**NOTE: Components A and C-F are now supplied in concentrated form.**

### Reagents & Supplies (Included with this experiment)

Store all components below at room temperature.

Component	Check (✓)
• UltraSpec-Agarose™	<input type="checkbox"/>
• Electrophoresis Buffer (50x)	<input type="checkbox"/>
• SYBR® Safe Stain	<input type="checkbox"/>
• FlashBlue™ Liquid Stain	<input type="checkbox"/>
• Microcentrifuge Tubes	<input type="checkbox"/>
• 0.2 mL PCR tubes	<input type="checkbox"/>



EDVOTEK and The Biotechnology Education Company are registered trademarks of EDVOTEK, Inc. SYBR is a registered trademark of Thermo Fisher Scientific. EdvoQuick, EdvoBead, FlashBlue, LyphoTemplate, LyphoPrimer, DuraGel, and UltraSpec-Agarose are trademarks of EDVOTEK, Inc.

1.800.EDVOTEK • Fax 202.370.1501 • info@edvotek.com • www.edvotek.com

Duplication of any part of this document is permitted for non-profit educational purposes only. Copyright © 2006-2015 EDVOTEK, Inc., all rights reserved. 371.181117



## Requirements *(NOT included with this experiment)*

---

- Thermal cycler (EDVOTEK Cat. #541 highly recommended)
- Horizontal gel electrophoresis apparatus
- D.C. power supply
- Microcentrifuge
- UV Transilluminator or Blue Light visualization (EDVOTEK Cat. #558 or #557 highly recommended)
- White light visualization system (OPTIONAL - use if staining with FlashBlue™)
- UV safety goggles
- Automatic micropipettes (5-50 µL) with tips
- Microwave
- 250 mL flasks or beakers
- Hot gloves
- Disposable laboratory gloves



## Background Information

### VARIABILITY IN THE HUMAN GENOME ALLOWS FOR THE CREATION OF DNA FINGERPRINTS

The human genome is 99.9% identical between individuals. However, there are regions of variation within our genome called polymorphisms. Each of us inherits a unique combination of polymorphisms from our parents. By focusing on several polymorphic regions scientist can uncover a person's "DNA fingerprint". Like a regular fingerprint, a DNA fingerprint can be used to identify and distinguish between individuals. Because polymorphisms are inherited, DNA fingerprints can also be used to determine family relationships. DNA fingerprinting is used for the identification of missing persons and human remains, the determination of parentage, and the matching of criminal suspects to crime scenes.

DNA fingerprinting is used extensively in the field of forensic science. It establishes the probability that Sample X from the crime scene came from Person Y. Sir Alex Jeffreys first developed this method in 1984 at the University of Leicester, England. In 1986 analysis by Jeffreys led to the acquittal of Richard Buckland from murder charges. In 1987 Colin Pitchfork was the first criminal caught and convicted using DNA fingerprinting. Since then DNA analysis has been used in thousands of convictions. Additionally, hundreds of convicted prison inmates have been exonerated from their crimes.

The goal of DNA fingerprinting is to analyze the genetic sample in a way that shows the tiny differences in the DNA of different people. In the early days of DNA fingerprinting analysis, this was done using restriction fragment length polymorphisms. Restriction enzymes recognize and cut DNA at specific nucleotide sequences. When added to a sample, restriction enzymes create fragments of DNA that differ in length based on the presence or absence of these sequences. These differences are visualized using gel electrophoresis followed by southern blotting and hybridization to a labeled probe. An RFLP is demonstrated whenever the Southern blot pattern obtained with one individual is different from the one obtained with another individual. This method is accurate but requires a considerable amount of starting material.

**Figure 1:**  
PCR Amplification  
Products of D7S820

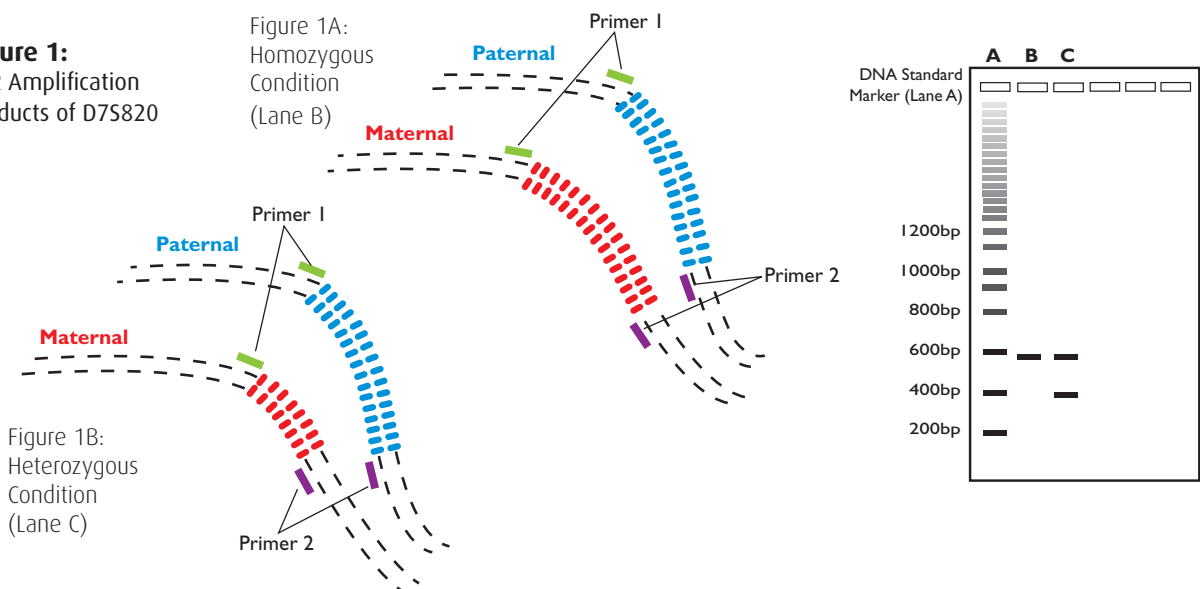

Today, DNA fingerprinting is based on short repeat regions that can be analyzed even when they come from a small amount of degraded DNA sample. Individuals possess regions within their chromosomal DNA that are non-coding and that contain repeating units of nucleotides. These are called VNTRs (Variable Number of Tandem Repeats) when the nucleotide repeats are 15 to 70 bp long and STR (Short Tandem Repeats) when the nucleotide repeats are 2 to 6 bp long. VNTRs and STRs can repeat anywhere between three times and a hundred times. Each repeat forms an allele of a specific size. An example of an STR is D7S820, found on chromosome 7, which contains between 5 and 16 repeats of "GATA". Humans have two copies of this genetic locus – one from our biological mother and one from our biological father. This means we have two alleles at this site. If both alleles are the same the individual is homozygous and if the alleles are different the individual is heterozygous at D7S820 (Figure 1). Because D7S820 can be many different lengths, there are hundreds of different allele combinations that can occur at this location.

The power of STR analysis comes from looking at multiple STR loci simultaneously. Thirteen independent loci have been established as the standard for human identification - CSF1PO, FGA, TH01, TPOX, VWA, D3S1358, D5S818, D7S820, D8S1179, D13S317, D16S539, D18S51 and D21S11. The probability of a random match when all 13 loci are analyzed is 1 in 3 trillion. In 1990, the Federal Bureau of Investigation (FBI) established the Combined DNA Index System (CODIS), based on these thirteen STRs (Figure 2). CODIS is a database system which allows comparison of crime scene DNA to DNA profiles in a convicted offender and a forensic (crime scene) index. A match of crime scene DNA to a profile in the convicted offender index indicates a suspect for the crime, whereas a match of crime scene DNA to the forensic index (a different crime scene) indicates a serial offender. CODIS has now been used to solve dozens of cases where authorities had not been able to identify a suspect for the crime under investigation.

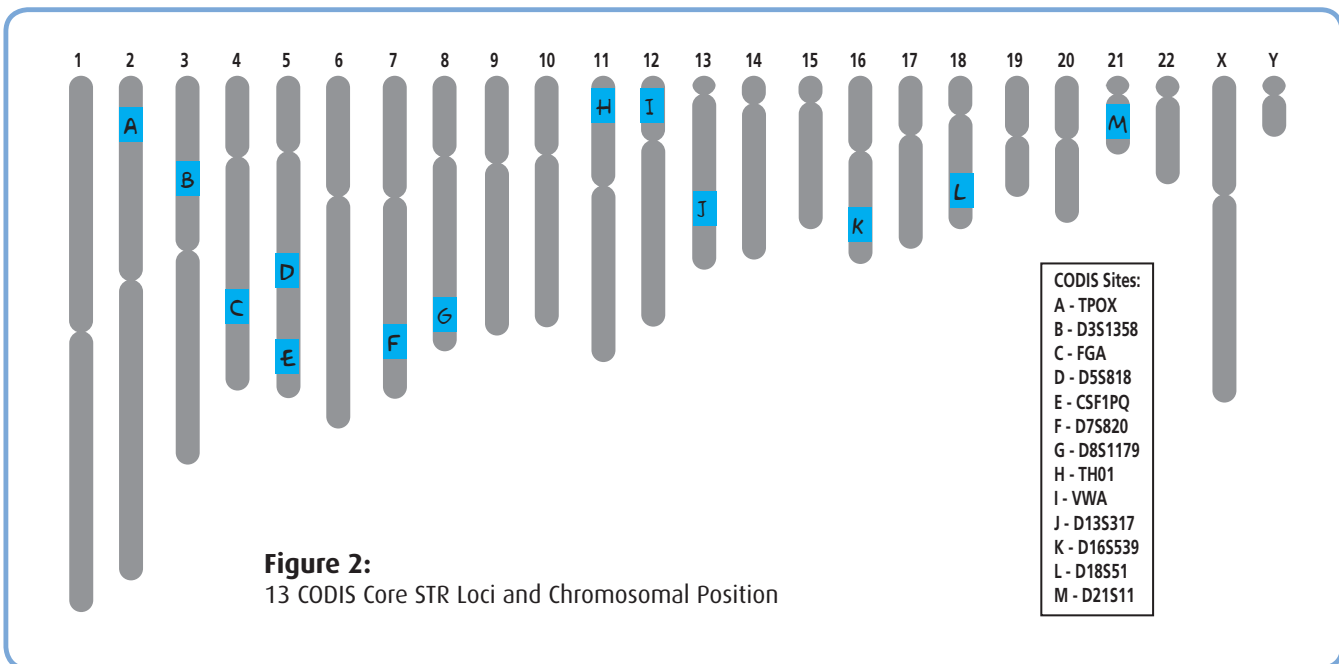



## CREATING A DNA FINGERPRINT FROM A CRIME SCENE SAMPLE

Forensic DNA fingerprinting begins with the legal collection of biological evidence (often present as a stain) from the crime scene or victim. The sample is treated with a detergent to rupture (lyse) cell membranes, and the cellular DNA is extracted for further analysis (Figure 3). After DNA is extracted from the sample, forensic scientists can develop a DNA fingerprint. The DNA fingerprint from a crime scene can then be compared to the DNA fingerprints of different suspects. A match provides strong evidence that the suspect was present at the crime scene.

In today's forensics laboratories, the polymerase chain reaction (or PCR) is used to create a DNA fingerprint. During PCR, DNA is copied in vitro much like it is during replication in a dividing cell. While many enzymes are involved in replication, PCR uses one enzyme and instead changes the temperature to initiate different steps. The first step for both PCR and replication is for two complementary DNA strands to separate from one another. In PCR, this is accomplished by heating the sample to 94°C, which breaks the hydrogen bonds between the base pairs. This step is known as denaturing.

In the second step of DNA replication, the enzyme Primase places small RNA primers on the single stranded DNA to target the genome for replication by polymerase. To replicate this in vitro, scientists create short, synthetic pieces of DNA that target a specific part of the genome. Primers have sequences unique to the regions above and below the sequence of interest (Figure 1). These primers bind to their specific DNA match and in turn serve as an attachment site for DNA polymerase. In PCR, the sample is cooled to an intermediate temperature, usually 40°C to 65°C, to allow binding of the two primers to the target DNA in a process called annealing.

In the third step of replication and PCR, an enzyme called polymerase duplicates the DNA molecule by reading the template DNA strand (starting from the primer) and assembling the appropriate nucleotides into a complementary strand. In PCR, this is accomplished by raising the temperature to 72°C, which is the optimal temperature for polymerase to synthesize the new complementary strand. An important difference between PCR and replication is that in PCR a small section of the genome is amplified (as dictated by the primers) rather than the whole genome.

These three steps - denaturation, annealing, and extension - constitute one cycle of PCR. Each cycle doubles the amount of targeted DNA (see Figure 4), exponentially increasing the amount of DNA in the sample. These three distinct temperature steps are repeated many times. When these cycles are repeated 20-40 times, the amount of target sequence increases to the point that it can be easily examined. To simplify this process, a specialized machine, called a "thermal cycler" or a "PCR machine", was created to rapidly heat and cool the samples.

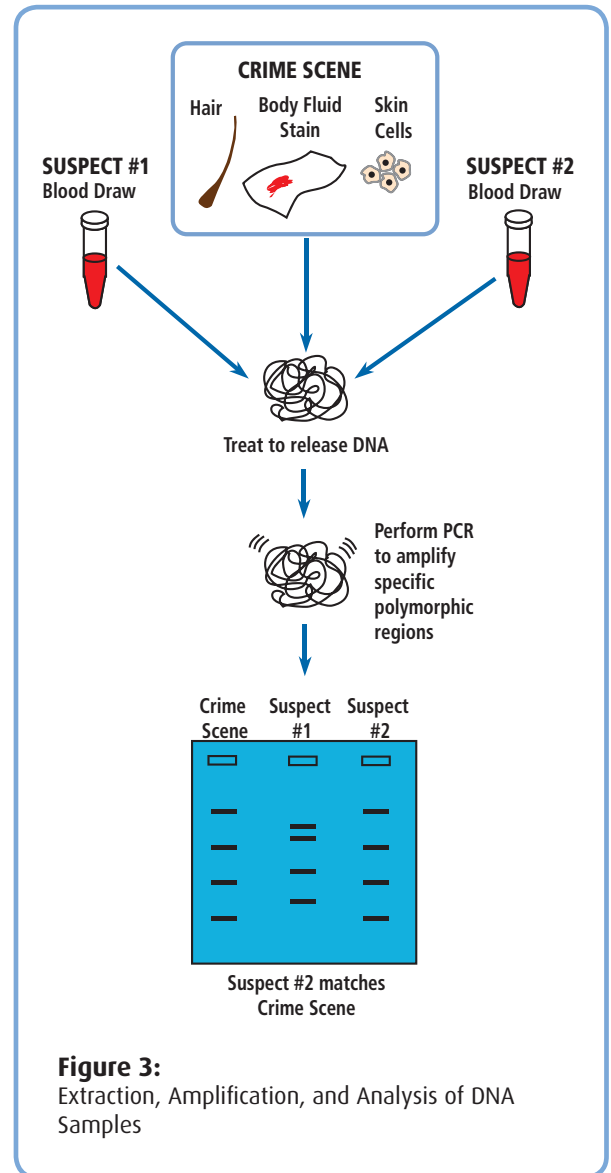

**Figure 3:**  
Extraction, Amplification, and Analysis of DNA Samples

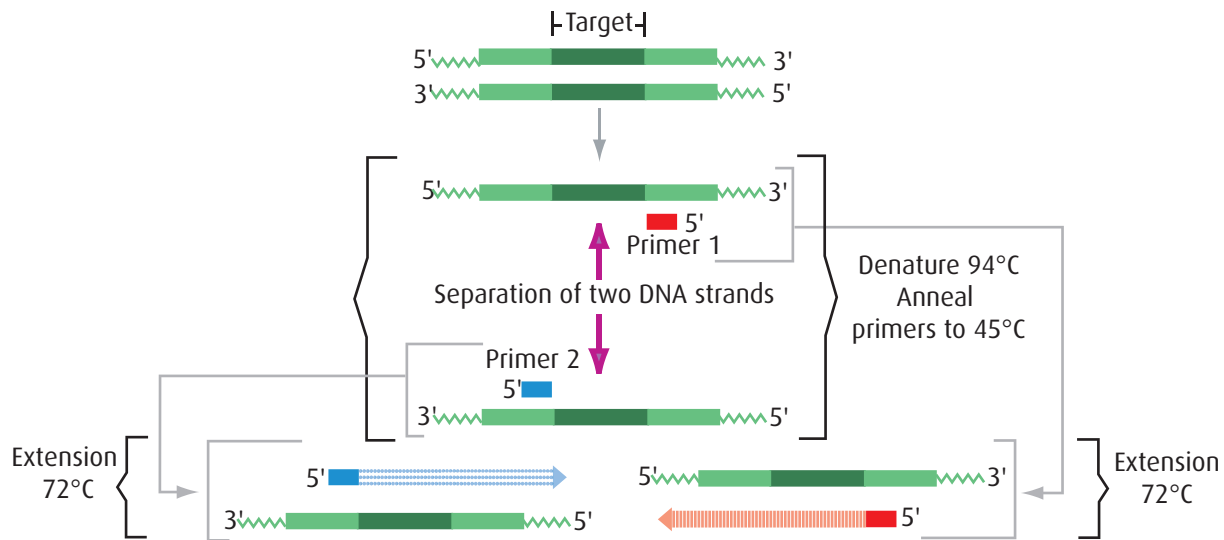
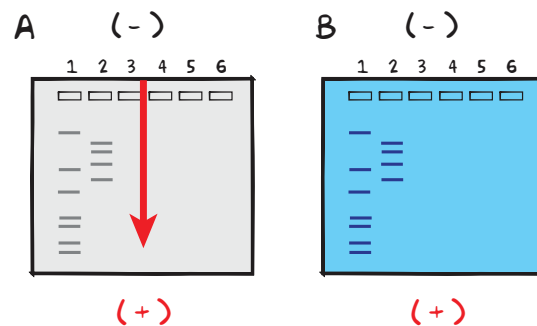

**Figure 4:** Polymerase Chain Reaction

Because PCR occurs in a test tube, scientists must provide the key ingredients of nucleotides, primers, the initial DNA template, and DNA polymerase. For PCR to be successful, this polymerase must be stable at high temperatures so that it is not denatured each time the PCR sample is raised to 94°C. To combat this problem, the thermostable DNA polymerase “*Taq*” was isolated from the bacterium *Thermus aquaticus*.

Following amplification, the PCR products are visualized and sized using gel electrophoresis. In gel electrophoresis the amplified product is added into depressions (or “wells”) within a gel, and then an electrical current is passed through the gel. Because the sugar-phosphate backbone of DNA has a strong negative charge, the current drives the DNA through the gel towards the positive electrode. On the molecular level, the gel contains small channels through which the DNA can pass. Small DNA fragments move through these holes easily, but large DNA fragments have a more difficult time squeezing through the tunnels. Because molecules with dissimilar sizes travel at different speeds, they become separated and form discrete “bands” within the gel. After the current is stopped, the bands can be visualized using a stain that sticks to DNA (Figure 5). The loci’s length is then calculated by comparing the distance the band traveled to a DNA ladder made up of several known lengths. In forensic analysis this process of amplification, visualization, and measurement is repeated for several loci.

In this experiment, students and teachers will design their own crime scene and develop a plan to test their crime-solving skills using PCR and gel electrophoresis.



**Figure 5:**  
Overview of Agarose Gel Electrophoresis



## Experiment Overview

### EXPERIMENT OBJECTIVE:

In this experiment, students will conduct a DNA fingerprinting exercise on simulated samples from a crime scene and four different suspects. Polymorphic regions of DNA are amplified using PCR. Students will then analyze the amplified DNA segments by agarose gel electrophoresis.

### LABORATORY SAFETY

1. Gloves and goggles should be worn routinely as good laboratory practice.
2. Exercise extreme caution when working with equipment that is used in conjunction with the heating and/or melting of reagents.
3. DO NOT MOUTH PIPET REAGENTS - USE PIPET PUMPS.
4. Exercise caution when using any electrical equipment in the laboratory.
5. Always wash hands thoroughly with soap and water after handling reagents or biological materials in the laboratory.



### LABORATORY NOTEBOOKS:

Scientists document everything that happens during an experiment, including experimental conditions, thoughts and observations while conducting the experiment, and, of course, any data collected. Today, you'll be documenting your experiment in a laboratory notebook or on a separate worksheet.

#### Before starting the Experiment:

- Carefully read the introduction and the protocol. Use this information to form a hypothesis for this experiment.
- Predict the results of your experiment.

#### During the Experiment:

- Record your observations.

#### After the Experiment:

- Interpret the results – does your data support or contradict your hypothesis?
- If you repeated this experiment, what would you change? Revise your hypothesis to reflect this change.

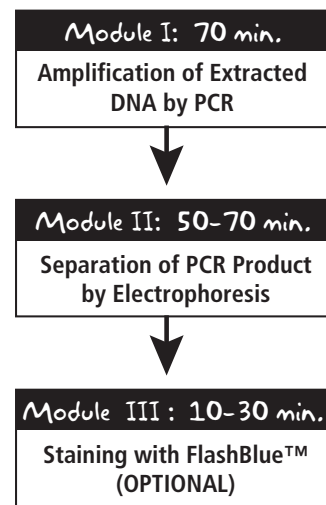

NOTE: Experimental times are approximate.

## Module I: PCR Amplification of Crime Scene and Suspect DNA

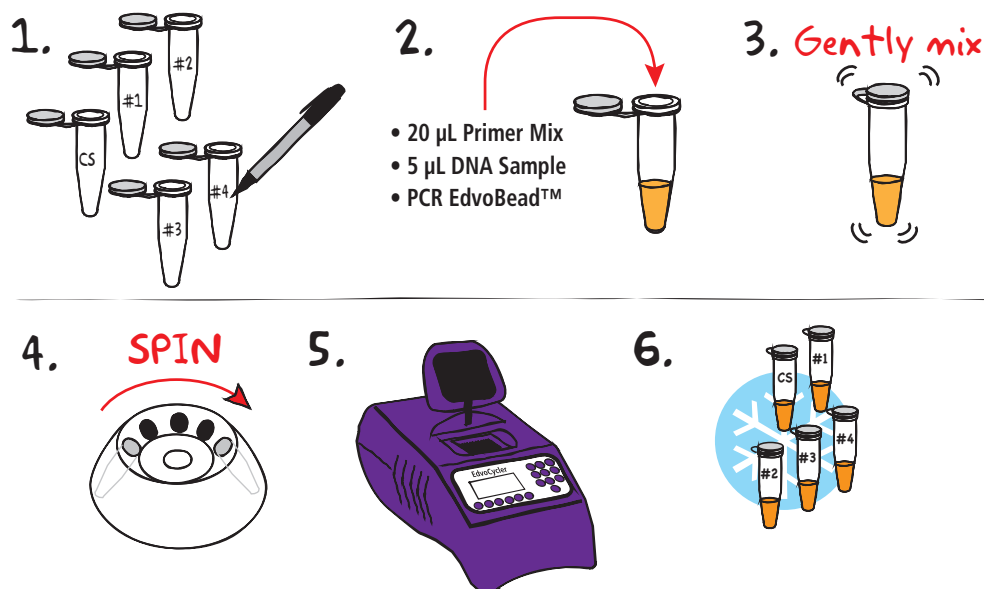

1. **LABEL** 5 PCR tubes for: Crime Scene (CS), Suspect 1 PCR (#1), Suspect 2 PCR (#2), Suspect 3 PCR (#3), and Suspect 4 PCR (#4). Put your initials or group number on the tubes.
2. All PCR reactions should be prepared as follows: **ADD** 20 µL primer mix (yellow), 5 µL DNA sample (red) and one PCR EdvoBead™ to the appropriately labeled 0.2 mL PCR tube.
3. **MIX** each PCR sample. Make sure the PCR EdvoBeads™ are completely dissolved. **NOTE: Double-check that both the primer and DNA have been added by looking at the color of the mixture in the PCR tube. The mixture should be orange with the primer and DNA mixed together.**
4. **CENTRIFUGE** the samples for a few seconds to collect the sample at the bottom of the tubes.
5. **AMPLIFY** the DNA using PCR:

### PCR cycling conditions:

Initial denaturation 94°C for 3 minutes  
 94° C for 30 seconds  
 55° C for 65 seconds } 30 cycles  
 72° C for 30 seconds }  
 Final Extension 72° C for 4 minutes

6. After PCR, **PLACE** the tubes on ice. **PROCEED** to Module II: Separation of PCR Products by Electrophoresis.



### OPTIONAL STOPPING POINT

The PCR samples may be stored at -20° C for electrophoresis at a later time.

## Module II: Separation of PCR Products by Electrophoresis

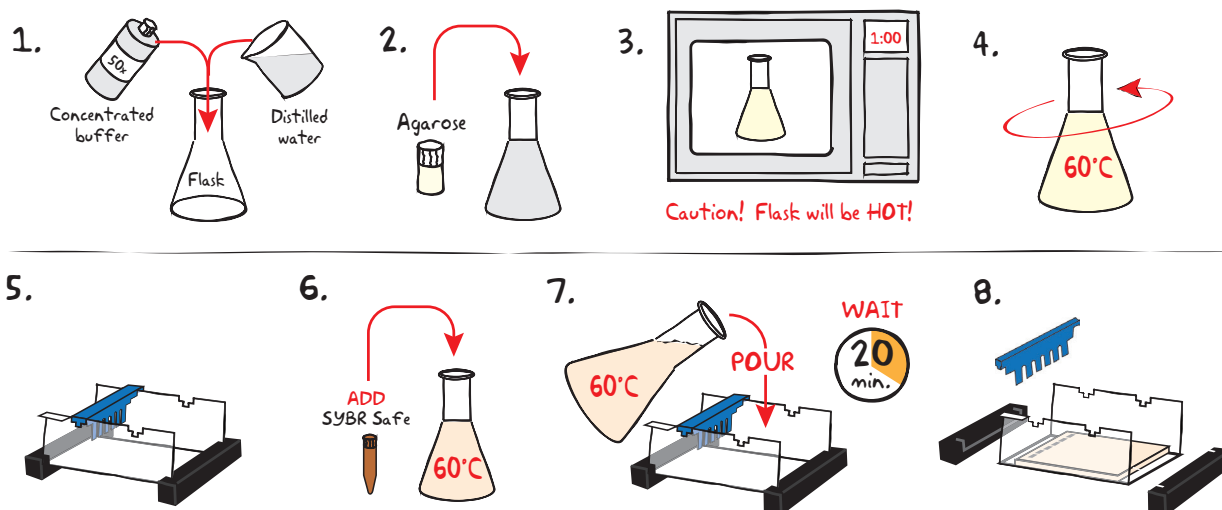

### PREPARING THE AGAROSE GEL WITH SYBR® SAFE STAIN

- DILUTE** concentrated (50X) buffer with distilled water to create 1X buffer (see Table A).
- MIX** agarose powder with 1X buffer in a 250 mL flask (see Table A).
- DISSOLVE** agarose powder by boiling the solution. **MICROWAVE** the solution on high for 1 minute. Carefully **REMOVE** the flask from the microwave and **MIX** by swirling the flask. Continue to **HEAT** the solution in 15-second bursts until the agarose is completely dissolved (the solution should be clear like water).
- COOL** the agarose to 60° C by carefully swirling the flask to promote even dissipation of heat.
- While the agarose is cooling, **SEAL** the ends of the gel-casting tray with the rubber end caps. **PLACE** the comb in the appropriate notch.
- Before casting the gel, **ADD** diluted SYBR® Safe stain to the cooled molten agarose and swirl to mix (see Table A).
- POUR** the cooled agarose solution into the prepared gel-casting tray. The gel should thoroughly solidify within 20 minutes. The gel will stiffen and become less transparent as it solidifies.
- REMOVE** the end caps and comb. Take particular care when removing the comb to prevent damage to the wells.



Wear gloves and safety goggles

#### IMPORTANT:

7 x 7 cm gels are recommended. Place the comb in the first set of notches.

If you are unfamiliar with agarose gel prep and electrophoresis, detailed instructions and helpful resources are available at [www.edvotek.com](http://www.edvotek.com)

Size of Gel Casting tray	Concentrated Buffer (50x)	+ Distilled Water	+ Amt of Agarose	= TOTAL Volume	Add SYBR® (Step 6)
7 x 7 cm	0.5 mL	24.5 mL	0.25g	25 mL	25 µL
7 x 14 cm	1.0 mL	49.0 mL	0.50 g	50 mL	50 µL

1.800.EDVOTEK • Fax 202.370.1501 • [info@edvotek.com](mailto:info@edvotek.com) • [www.edvotek.com](http://www.edvotek.com)

## Module II: Separation of PCR Products by Electrophoresis, continued

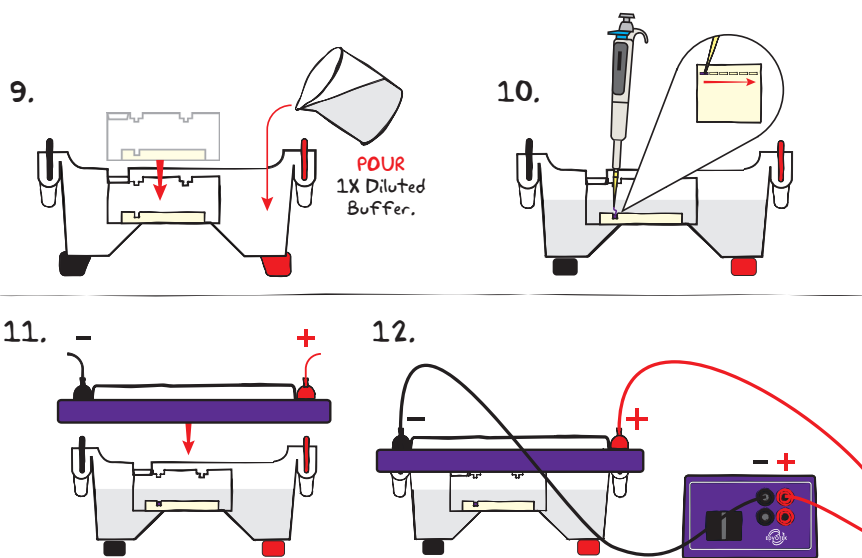
**Reminder:**

Before loading the samples, make sure the gel is properly oriented in the apparatus chamber.



Wear gloves and safety goggles

**RUNNING THE GEL**

- PLACE** the gel (on the tray) into the electrophoresis chamber. **COVER** the gel with 1X electrophoresis buffer (See Table B for recommended volumes). The gel should be completely submerged.
- LOAD** the entire volume (25  $\mu$ L) into the well in the order indicated by Table 1, right.
- CHECK** that the gel is properly oriented, then **PLACE** the safety cover onto the chamber. Remember, the DNA samples will migrate toward the positive (red) electrode.
- CONNECT** the leads to the power source and **PERFORM** electrophoresis (See Table C for time and voltage guidelines).
- After electrophoresis is complete, **REMOVE** the gel and casting tray from the electrophoresis chamber.

Table 1: Gel Loading

Lane 1	200 bp Ladder
2	Crime scene PCR
3	Suspect #1 PCR
4	Suspect #2 PCR
5	Suspect #3 PCR
6	Suspect #4 PCR

**OPTIONAL STOPPING POINT:**

Gels can be stored for several days. Place gel in a watertight plastic bag with 2 mL of electrophoresis buffer and store in the refrigerator.

Table B 1x Electrophoresis Buffer (Chamber Buffer)

EDVOTEK Model #	Total Volume Required	Dilution 50x Conc. Buffer + Distilled Water	
M6+	300 mL	6 mL	294 mL
M12	400 mL	8 mL	392 mL
M36	1000 mL	20 mL	980 mL

Table C Time and Voltage Guidelines (1.0% - 7 x 7 cm Agarose Gel)

Volts	Recommended Time	
	Minimum	Maximum
150	15 min.	20 min.
125	20 min.	35 min.
70	35 min.	1 hour

## Module II: Separation of PCR Products by Electrophoresis, continued

14.

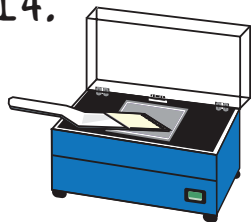

15.



16.

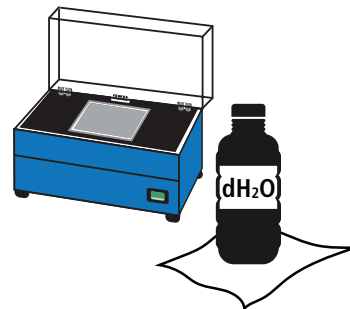

### VISUALIZING THE SYBR® GEL

14. **SLIDE** the gel off the casting tray onto the viewing surface of the transilluminator and turn the unit on. **ADJUST** the brightness to the desired level to maximize band visualization. DNA should appear as bright green bands on a dark background.
15. **PHOTOGRAPH** the results.
16. **REMOVE** and **DISPOSE** of the gel and **CLEAN** the transilluminator surfaces with distilled water.



Be sure to wear UV goggles if using a UV transilluminator.

## Module III: Staining with FlashBlue™ (OPTIONAL)

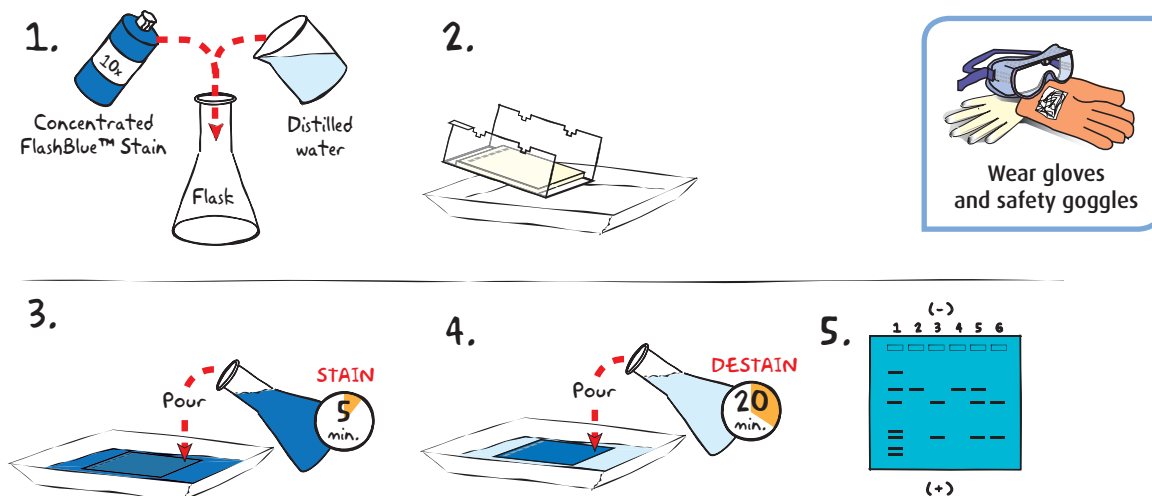

1. **DILUTE** 10 mL of 10x concentrated FlashBlue™ with 90 mL of water in a flask and **MIX** well.
2. **REMOVE** the agarose gel and casting tray from the electrophoresis chamber. **SLIDE** the gel off of the casting tray into a small, clean gel-staining tray.
3. **COVER** the gel with the 1x FlashBlue™ stain solution. **STAIN** the gel for 5 minutes. For best results, use an orbital shaker to gently agitate the gel while staining. **STAINING THE GEL FOR LONGER THAN 5 MINUTES WILL REQUIRE EXTRA DESTAINING TIME.**
4. **TRANSFER** the gel to a second small tray. **COVER** the gel with water. **DESTAIN** for at least 20 minutes with gentle shaking (longer periods will yield better results). Frequent changes of the water will accelerate destaining.
5. Carefully **REMOVE** the gel from the destaining liquid. **VISUALIZE** results using a white light visualization system. DNA will appear as dark blue bands on a light blue background.

### Alternate Protocol:

1. **DILUTE** one mL of concentrated FlashBlue™ stain with 149 mL dH<sub>2</sub>O.
2. **COVER** the gel with diluted FlashBlue™ stain.
3. **SOAK** the gel in the staining liquid for at least three hours. For best results, stain gels overnight.

## Study Questions

---

1. What is polymorphic DNA? How is it used for identification purposes?
2. What is an STR? Why is it used in law enforcement?
3. What are the three steps in a PCR cycle and what does each step accomplish?



# Instructor's Guide

## ADVANCE PREPARATION:

Preparation For:	What to do:	When:	Time Required:
<b>Module I: PCR Amplification of a Family's DNA</b>	Prepare and aliquot various reagents (Primer, DNA template, ladder, etc.)	Up to 2 hours before the experiment.	30 min.
	Program Thermal Cycler	Any time before performing the experiment.	15 min.
<b>Module II: Separation of PCR Product by Electrophoresis</b>	Prepare 1X Electrophoresis Buffer and dilute SYBR® Safe Stain	Up to one day before performing the experiment.	45 min.
	Prepare molten agarose and pour gel (optional)		
<b>Module III: Staining with FlashBlue™ (OPTIONAL)</b>	Prepare staining components	Any time before the class period.	10 min.

 Yellow = Prepare shortly before module.  Green = Flexible / prepare up to a week before the module.

### EDVO-TECH Service

**1.800.EDVOTEK**

Mon. - Fri. 8am-5:30pm EST



#### Please Have the Following Info:

- Product Number & Description
- Lot Number on Box
- Order/Purchase Order #
- Approx. Purchase Date

Fax: 202.370.1501 • [info@edvotek.com](mailto:info@edvotek.com) • [www.edvotek.com](http://www.edvotek.com)

**[www.edvotek.com](http://www.edvotek.com)**

- Online Catalog
- Order Products
- Experiment Protocols
- Tech Support
- Resources!



1.800.EDVOTEK • Fax 202.370.1501 • [info@edvotek.com](mailto:info@edvotek.com) • [www.edvotek.com](http://www.edvotek.com)

Duplication of any part of this document is permitted for non-profit educational purposes only. Copyright © 2006-2015 EDVOTEK, Inc., all rights reserved. 371.181117

## Pre-Lab Preparations

### MODULE I

This kit features the NEW EDVOTEK® LyphoPrimer™ and LyphoTemplate™. The reagents are color coded so that a correctly assembled PCR reaction should appear orange in color. These innovations will help ensure experimental success.

There are four different DNA samples provided. Choose one sample to represent the crime scene sample. (The designated CS sample can be different for different groups.) Make sure that one of the suspect DNAs is repeated as the crime scene sample for the respective groups. Alternatively, students can design their own crime scene scenario where they designate the DNAs for the crime scene and suspects.

In our scenario, the DNA sample for suspect #2 is repeated as the crime scene sample (see page 20).

#### Preparation of the DNA Template

1. Add 75  $\mu$ L TE Buffer (G) to each LyphoTemplate™ (C-F) and mix to dissolve.
2. Label twenty-five 1.5 mL snap-top microcentrifuge tubes as follows:
  - 5 - Crime Scene (CS)
  - 5 - Suspect 1 (#1)
  - 5 - Suspect 2 (#2)
  - 5 - Suspect 3 (#3)
  - 5 - Suspect 4 (#4)
3. Dispense 7  $\mu$ L of the DNA template into the appropriately labeled tube. Remember to use one of the suspect samples as the crime scene sample.

#### Preparation of the Primer

1. Add 1 mL of TE Buffer (G) to the tube of LyphoPrimer™ Mix (A). Cap tube and mix. The solution should be light yellow and no solid pieces should remain.
2. Pipette 120  $\mu$ L of the diluted Primer Mix into five labeled snap-top microcentrifuge tubes.
3. Distribute one tube of diluted Primer Mix to each student group.

#### Programming the Thermal Cycler

The Thermal cycler should be programmed as outlined in Module I in the Student's Experimental Procedure.

- Accurate temperatures and cycle times are critical. A pre-run for one cycle (takes approximately 3 to 5 min.) is recommended to check that the thermal cycler is properly programmed.
- For thermal cyclers that do not have a heated lid, it is necessary to place a layer of wax or mineral oil above the PCR reactions in the microcentrifuge tubes to prevent evaporation. Visit [www.edvotek.com](http://www.edvotek.com) for more information.

#### NOTE:

There is enough material to perform 25 PCR reactions and 5 gels. Students can be divided into groups of five students per group and samples from each group can be run on a gel. There is enough template DNA (Component C-F) for each group to perform a unique forensic crime scene scenario.

#### FOR MODULE I

##### Each Group should receive:

- 5 PCR tubes
- 5 PCR EdvoBeads™
- 7  $\mu$ L Crime Scene DNA
- 7  $\mu$ L Suspect #1 DNA
- 7  $\mu$ L Suspect #2 DNA
- 7  $\mu$ L Suspect #3 DNA
- 7  $\mu$ L Suspect #4 DNA
- 120  $\mu$ L Diluted Primer Mix



## Pre-Lab Preparations

### MODULE II: SEPARATION OF PCR PRODUCTS BY ELECTROPHORESIS

#### Preparation of Agarose Gels:

This experiment requires one 1.0% agarose gel per student group. For best results, we recommend using 7 x 7 cm gels. You can choose whether to prepare the gels in advance or have the students prepare their own. Allow approximately 30-40 minutes for this procedure.

#### Individual Gel Preparation

Each student group can be responsible for casting their own individual gel prior to conducting the experiment. See Module II in the Student's Experimental Procedure. Students will need 50x concentrated buffer, distilled water and agarose powder.

#### Batch Gel Preparation

To save time, a larger quantity of agarose solution can be prepared for sharing by the class (see Appendix B).

#### SYBR® Safe Stain Preparation

Prepare diluted SYBR® Safe by adding 250 µL of 1X TAE electrophoresis buffer to the tube of concentrated SYBR® Safe and tapping the tube several times to mix. For individual gel preparation, each group will need 25 µL of the diluted SYBR® Safe for a 7 x 7 cm gel. For Batch Gel Preparation, you will use the entire tube of SYBR® Safe (see Appendix B).

#### Preparing Gels in Advance

Gels may be prepared ahead and stored for later use. Solidified gels can be stored for up to a week in the refrigerator in plastic bags containing a small amount of buffer to prevent drying. We recommend adding only 2 mL of buffer to the bag to prevent SYBR® Safe Stain from diffusing out of the gel.

Do not store gels at -20° C because freezing will destroy them.

Gels that have been removed from their trays for storage should be "anchored" back to the tray with a few drops of molten agarose before being placed into the tray. This will prevent the gels from sliding around in the trays and the chambers.

#### Additional Materials

Each 1.0% gel should be loaded with the EdvoQuick™ DNA ladder and PCR reactions from one student group.

- Pipette 30 µL of the EdvoQuick™ DNA ladder (B) into labeled microcentrifuge tubes and distribute one tube of EdvoQuick™ DNA ladder per gel.

#### NOTE:

Accurate pipetting is critical for good experiment results. This experiment is designed for students who have had previous experience with micropipetting techniques and agarose gel electrophoresis.

If students do not know how to use micropipettes, we recommend performing Cat. #S-44, Micropipetting Basics or Cat. #S-43, DNA DuraGel™ prior to conducting this advanced level experiment.

#### FOR MODULE II

##### Each Group should receive:

- 50x concentrated buffer
- Distilled Water
- UltraSpec-Agarose™ Powder
- 25 µL diluted SYBR® Safe Stain
- 30 µL EdvoQuick DNA ladder
- PCR Samples from Module I

#### NOTE:

QuickGuide instructions and guidelines for casting various agarose gels can be found on our website.

[www.edvotek.com/quick-guides](http://www.edvotek.com/quick-guides)

Cat. #557

#### TruBlu™ LED Transilluminator

The all-new TruBlu™ LED Transilluminator utilizes blue light to view DNA gels stained with SYBR® Safe, thus eliminating the need for UV light or ethidium bromide. The spacious viewing area fits multiple agarose gels. And the high intensity control and orange lid ensure superior visualization.

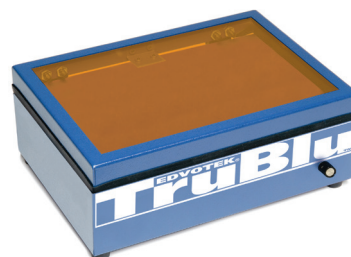

#### Features:

- 14.5 x 18 cm viewing area
- Blue light intensity control
- Orange contrast lid
- Durable steel casing
- Made in the USA

## Pre-Lab Preparations: Module III

### MODULE III: STAINING WITH FLASHBLUE™ (OPTIONAL)

FlashBlue™ stain is optimized to shorten the time required for both staining and destaining steps. Agarose gels can be stained with diluted FlashBlue™ for 5 minutes and destained for only 20 minutes. For the best results, leave the gel in liquid overnight. This will allow the stained gel to “equilibrate” in the destaining solution, resulting in dark blue DNA bands contrasting against a uniformly light blue background. A white light box (Cat. #552) is recommended for visualizing gels stained with FlashBlue™.

- Stained gels may be stored in destaining liquid for several weeks with refrigeration, although the bands may fade with time. If this happens, re-stain the gel.
- Destained gels can be discarded in solid waste disposal. Destaining solutions can be disposed of down the drain.

#### Photodocumentation of DNA

Once gels are stained, you may wish to photograph your results. There are many different photodocumentation systems available, including digital systems that are interfaced directly with computers. Specific instructions will vary depending upon the type of photodocumentation system you are using.



Wear gloves  
and safety goggles

#### FOR MODULE III Each Student Group should receive:

- 10 mL 10X concentrated FlashBlue OR 100 mL 1x diluted FlashBlue
- Small plastic tray or weight boat
- Distilled or deionized water

## Experiment Results and Analysis

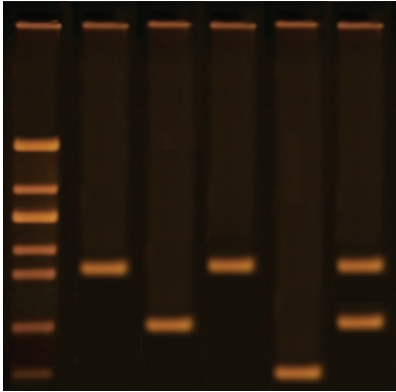

Lane	Sample	Sizes
1	EdvoQuick™ DNA Ladder	2640, 1400, 1100, 700, 600, 400, 200
2	Crime Scene DNA	625
3	Suspect #1 DNA	400
4	Suspect #2 DNA	625
5	Suspect #3 DNA	200
6	Suspect #4 DNA	625, 400

### ANALYSIS:

The above is an example outcome of this exercise, in which we chose Suspect #2 to match the crime scene DNA. Your results for the crime scene DNA will vary depending on which suspect was selected.

In criminal investigations, several known variable regions in DNA are analyzed to match crime scene and suspect DNAs. In this exercise, we are analyzing one of these variable regions. A match between the crime scene DNA and a suspect provides strong evidence that the suspect was present at the crime scene. After analyzing the samples, a match was made between the crime scene DNA in lane 2 and Suspect #2 in lane 4. This is strong evidence that suspect #2 was at the crime scene, but it does not prove that this suspect committed the crime.

The EdvoQuick™ DNA Ladder in lane 1 makes it possible to measure the size of the amplicons produced by the PCR reactions in lanes 2-6.

### Includes EDVOTEK's All-NEW EdvoQuick™ DNA Ladder

- Better separation
- Easier band measurements
- No unused bands

EdvoQuick™ DNA ladder sizes:  
2640, 1400, 1100, 700, 600, 400, 200



**Please refer to the kit  
insert for the Answers to  
Study Questions**

# Appendices

- A EDVOTEK® Troubleshooting Guide
- B Bulk Preparation of Electrophoresis Buffer and Agarose Gels

Safety Data Sheets can be found on our website:  
[www.edvotek.com/safety-data-sheets](http://www.edvotek.com/safety-data-sheets)

## EDVO-TECH Service

**1.800.EDVOTEK**

Mon. - Fri. 8am-5:30pm EST



### Please Have the Following Info:

- Product Number & Description
  - Lot Number on Box
- Order/Purchase Order #
- Approx. Purchase Date

Fax: 202.370.1501 • [info@edvotek.com](mailto:info@edvotek.com) • [www.edvotek.com](http://www.edvotek.com)

**www.edvotek.com**

- Online Catalog
- Order Products
- Experiment Protocols
- Tech Support
- Resources!





## Appendix A

### EDVOTEK® Troubleshooting Guides

#### PCR AND ELECTROPHORESIS

PROBLEM:	CAUSE:	ANSWER:
There is very little liquid left in tube after PCR.	Sample has evaporated.	<p>Make sure the heated lid reaches the appropriate temperature.</p> <p>If your thermal cycler does not have a heated lid, overlay the PCR reaction with wax (see <a href="http://www.edvotek.com">www.edvotek.com</a> for more info).</p> <p>Make sure students close the lid of the PCR tube properly.</p>
	Pipetting error.	Make sure students pipet 20 µL primer mix and 5 µL DNA into the 0.2 mL tubes.
The ladder, control DNA, and PCR products are not visible on the gel.	The gel was not prepared properly.	<p>Ensure that the electrophoresis buffer was correctly diluted.</p> <p>Gels of higher concentration (&gt; 0.8%) require special attention when melting the agarose. Make sure that the solution is completely clear of "clumps" and glassy granules before pouring gels.</p>
	The gel was not stained properly.	Repeat staining.
	Malfunctioning electrophoresis unit or power source.	Contact the manufacturer of the electrophoresis unit or power source.
After staining the gel, the DNA bands are faint.	The gel was not stained for a sufficient period of time.	Repeat staining protocol.
After staining, the ladder is visible but no PCR products are present.	PCR amplification was unsuccessful.	Repeat PCR with fresh PCR EdvoBeads™ and primers.
		Ensure that the thermal cycler has been properly programmed. See Module I for guidelines.
DNA bands were not resolved.	Blue tracking dye <b>in ladder</b> should migrate at least 3.5 cm (if using a 7x7 cm tray), and at least 6 cm (if using a 7x14 cm tray) from the wells to ensure adequate separation.	Be sure to run the gel at least 3.5 cm (7x7 cm tray) or 6 cm (7x14 cm tray) before staining and visualizing the DNA. (See Table C for time and voltage guidelines.)
DNA bands fade when gels are kept at 4°C.	DNA stained with FlashBlue™ may fade with time.	Re-stain the gel with FlashBlue™.

## Appendix B

### Bulk Preparation of Electrophoresis Buffer and Agarose Gels

To save time, the electrophoresis buffer and agarose gel solution can be prepared in larger quantities that the whole class can share. Leftover diluted buffer can be used at a later time and solidified agarose gel solution can be remelted.

#### Bulk Electrophoresis Buffer

Quantity (bulk) preparation for 3 liters of 1x electrophoresis buffer is outlined in Table D.

50x Conc. Buffer	+	Distilled Water	Total Volume 1X Buffer
60 ml		2,940 ml	3000 ml (3 L)

#### Batch Agarose Gels (1.0%)

For quantity (batch) preparation of 1.0% agarose gels, reference Table E.

1. Use a 500 mL flask to prepare the 1X Diluted gel buffer.
2. Pour the measured UltraSpec-Agarose™ into the prepared buffer. Refer to Table E for the mass. Swirl to disperse clumps.
3. With a marking pen, indicate the level of solution volume on the outside of the flask.
4. Heat the agarose solution as outlined previously for individual gel preparation. The heating time will require adjustment due to the larger total volume of gel buffer solution.
5. Cool the agarose solution to 60° C with swirling to promote even dissipation of heat. If evaporation has occurred, add distilled water to bring the solution up to the original volume as marked on the flask in step 3.
6. If staining with SYBR® Safe, add the entire volume of diluted SYBR® Safe, prepared on page 17, to the cooled agarose. This concentration of SYBR® Safe will work for either 300 mL or 400 mL preparations of agarose gels.
7. Dispense the required volume of cooled agarose solution for casting each gel. Measure 25 mL for each 7 x 7 cm gel, 50 mL for each 7 x 14 cm gel. **For this experiment, 7 x 7 cm gels are recommended.**
8. Allow the gel to completely solidify. It will become firm and cool to the touch after approximately 20 minutes. Then proceed with preparing the gel for electrophoresis. Alternatively, gels can be stored in water-tight plastic bags with 2 mL of 1X electrophoresis buffer for up to 1 week in the refrigerator.

50x Conc. Buffer	+	Distilled Water	+	Amt of Agarose	=	Total Volume
6.0 ml		294 ml		3.0 g		300 ml
8.0 ml		392 ml		4.0 g		400 ml

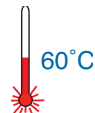

#### NOTE:

The UltraSpec-Agarose™ kit component is usually labeled with the amount it contains. Please read the label carefully. If the amount of agarose is not specified or if the bottle's plastic seal has been broken, weigh the agarose to ensure you are using the correct amount.

#### NOTE:

QuickGuide instructions and guidelines for casting various agarose gels can be found on our website. [www.edvotek.com/quick-guides](http://www.edvotek.com/quick-guides)